

TAD

**TAD Compact Reference One
TAD-CR1TX**

**SPEAKER SYSTEM
OWNER'S MANUAL**

BEFORE USING

Thank you for buying this TAD product. Please read through these operating instructions so you will know how to operate your model properly. After you have finished reading the instructions, put them away in a safe place for future reference.

- This speaker system has an impedance of 4 ohms, and should be connected only to an amplifier designed with a load impedance of 4 ohms (the amplifier's speaker output connector should clearly be labeled "4 ohms").

In order to prevent damage to the speaker system resulting from input overload, please observe the following precautions:

- Do not supply power to the speaker system in excess of the maximum permissible input.
- Always turn off the amplifier power whenever connecting this unit or other components to the amplifier.
- Be careful not to overload the amplifier by playing at high sound levels, as the amplifier's harmonic distortion will be increased and you may damage the speaker.

Caution: installation

- Do not place the speaker on an unstable surface. It could present a hazard if it falls, as well as potentially damaging the equipment.
- Do not attach these speakers to the wall or ceiling. They may fall off and cause injury.
- Switch off and unplug your AV equipment and consult the instructions when connecting up components. Make sure you use the correct connecting cables.
- Technical Audio Devices, Inc. is not responsible for any accidents or damage that result from improper installation, misuse or modification of the product, or natural disasters.

Caution: in use

- Do not allow the speaker to output distorted sound for long periods of times. This is an indication of using excessive power and can result in a fire hazard.
- Do not sit or stand on the speaker, or let children play on the speaker.
- Do not put any objects on top of the speaker.
- Do not place magnetic objects such as screwdrivers or iron parts near the tweeter or midrange. Since the speakers use strong magnets, the objects may be attracted, causing injury or damaging the diaphragm.

IMPORTANT NOTICE

THE MODEL NUMBER AND SERIAL NUMBER OF THIS EQUIPMENT ARE ON THE REAR OR BOTTOM. RECORD THESE NUMBERS IN THE SPACE BELOW FOR FUTURE REFERENCE.

MODEL NO. _____
SERIAL NO. _____

D36-AP9-2_A1_En

For European model



If you want to dispose this product, do not mix it with general household waste. There is a separate collection system for used electronic products in accordance with legislation that requires proper treatment, recovery and recycling.

Private households in the member states of the EU, in Switzerland and Norway may return their used electronic products free of charge to designated collection facilities or to a retailer (if you purchase a similar new one).

For countries not mentioned above, please contact your local authorities for the correct method of disposal.

By doing so you will ensure that your disposed product undergoes the necessary treatment, recovery and recycling and thus prevent potential negative effects on the environment and human health.

K058b_A1_En

Contents

- INTRODUCTION 4**
- Inspiring the joy of listening 4
- TAD Compact Reference Description..... 4
- TECHNOLOGY 5**
- Beryllium Diaphragms 5
- CST..... 5
- Bass Drivers 6
- CST Mounting Construction 7
- Bass Enclosure Construction 7
- Crossover Networks..... 7
- Enclosure Finish 7
- INSTALLATION AND CARE 8**
- Installation..... 8
- Installing The Spikes 9

- Removing The Grille Covers..... 9
- Choosing Where To Place The Speakers..... 10
- Speaker care 10
- CONNECTING THE SPEAKERS 11**
- Single-Wire Connections 11
- Bi-Wire Connections 12
- Bi-Amplification Connections 13
 - Vertical Bi-Amping 13
 - Horizontal Bi-Amping 14
- OPTIMIZING THE SYSTEM..... 15**
- Improving Bass Performance..... 15
- Improving Imaging 15
- Final Optimization 15
- SPECIFICATIONS 16**

Parts Included

Verify that following items are included in the box of accessory kit.

- Shorting links x 2

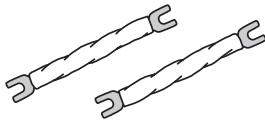

- Cone-shaped spikes x 3



- Round spikes x 3



- Spike bases x 3



- Cork sheets x 3



WARNING

Store small parts out of the reach of children and infants. If accidentally swallowed, contact a doctor immediately.

- Cleaning cloth x 1

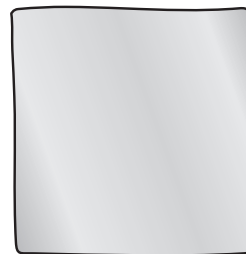

- This Owner's Manual (English) x 1

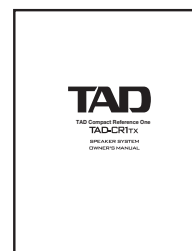

- Owner's Manual (Japanese & French editions) x 1
- Warranty card (This warranty is valid only in Japan.)

Note

Included parts may vary slightly by region.

INTRODUCTION

Inspiring the joy of listening

Technical Audio Devices Laboratories, Inc. (TADL) grew from the spirit to discover technologies to perfectly recreate the pure sound of life performances with uncompromising craftsmanship. We have inherited our philosophy from Bart Locanthi –recognized across the globe as the ultimate sound technologist—who believed that genuine technology is true to the basic and that genuine technology places greater importance on sound quality than on technology for its own sake. At TADL, we are honing our technology to create equipment that reproduces musical sounds that evoke both the energy and impact of life music.

TAD Compact Reference Description

The TAD Compact Reference speaker system is a revolutionary product for home audio, and represents the culmination of over 40 years experience in developing class-leading loudspeakers for the professional studio monitoring environment.

Central to the performance of the TAD Compact Reference speaker system is the Coherent Source Transducer (CST), a concentric unit featuring TAD's unique beryllium-diaphragm design. Beryllium is used for both the tweeter dome and the midrange cone, to provide a point source radiator covering the frequency range from 250 Hz to 100 kHz.

The CST is supplemented by a 20 cm (8 inch) bass driver enclosed in structurally inert cabinet. The result is a very wide-band, resonance-free monitor speaker of the highest quality.

Beryllium Diaphragms

Each TAD Compact Reference speaker system features proprietary beryllium-manufacturing technology for the midrange and tweeter diaphragms. The lightest and most rigid metal available for diaphragms, beryllium performs with strength and damping characteristics unmatched by any of the materials currently used in high-end audio loudspeaker manufacturing, as shown in Figure 1.

Beryllium's combination of light weight and exceptional strength enables diaphragm resonance to be pushed far beyond the operating band of its drive units. This produces near-perfect piston behavior in the speakers, resulting in cleaner sound and greater accuracy of reproduction.

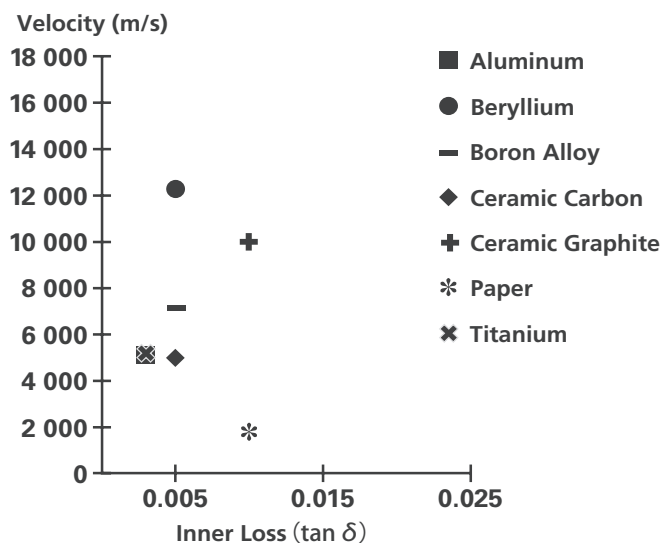

Figure 1. Velocity properties of beryllium and other materials.

CST

The heart of the system is the Coherent Source Transducer (CST), shown in Figure 2. The tweeter diaphragm is mounted concentrically within the apex of the midrange cone and provides a point source of sound from 250 Hz to 100 kHz. It is time coherent, due to the shallow midrange-cone profile made possible by the superior strength of beryllium, and produces a superbly controlled radiation pattern.

CST ensures a perfect spectral balance between the direct and reflected sounds that arrive at the listener's ears, providing a more consistent sound throughout the listening room and improved imaging capability.

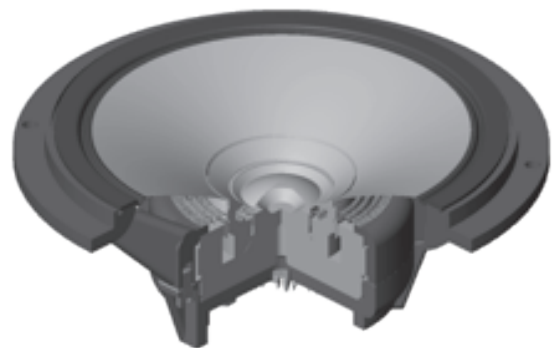

Figure 2. The TAD Compact Reference's Coherent Source Transducer

Bass Drivers

The foundation of the TAD Compact Reference speaker system is the bass driver, as shown in Figure 3. The driver cone is constructed from a tri-laminate of front and rear-woven aramid fibers that sandwich a foamed acrylic core. This provides enormous strength to the cone in order to resist any flexing due to the high forces exerted during loud bass passages. To achieve high drive linearity, the motor structure employs short coil, long-gap geometry, Faraday shorting rings and a novel flux path design. The speaker also features a newly designed spider and multi-roll surround for the best possible measures against distortion.



Figure 3. The TAD Compact Reference's Bass Driver

CST Mounting Construction

The CST driver is mounted into an extremely rigid enclosure that features a baffle specially formed to optimize the sound emitted from the driver.

To further enhance the performance, ISO-Drive technology is used to mechanically isolate the CST driver from its cabinet. This greatly reduces the mechanical energy that is the source for enclosure vibration, resulting in reduced delayed resonances and improved resolution of fine detail.

Bass Enclosure Construction

The wafer enclosure for the TAD Compact Reference is a robust structure with the framework made of birch plywood with 21 mm thickness, clad with lateral plates of 30 mm thickness, which are formed by high-frequency proximity heating compression molding.

The bass reflex port was modeled after the design concept of the TAD compression driver and horn, resulting in the reduction of wind noise for clear, deep bass.

The 46 kg (101.4 lb) mass of this system produces a correspondingly powerful bass sound that is both clean and subtle. The teardrop-shape both reduces sound diffraction, allowing for excellent acoustics, and also serves to eliminate unnecessary resonance and internal standing waves.

Crossover Networks

The crossover networks use only the finest components. Air cored coils, noninductive resistors, and film capacitors in the signal path are all carefully chosen and optimized for the CST driver to provide the greatest transparency to the signal.

The bass driver uses laminated steel-core inductors for highpower handling and low saturation.

All components are built on high-grade, glass-epoxy, printed circuit boards with thick copper traces to ensure stability and repeatability of performance.

Enclosure Finish

The enclosure features rare, elegant natural wood that is treated with a transparent finish. Its surface has a beautifully polished mirrored finish, the result of the meticulous, painstaking work of skilled craftsmen.

This product is designed to elicit the full potential of the natural wood used in its enclosure. Note that the color and pattern of the wood is slightly different for each unit.

TAD x Tendo Mokko

"Tendo Mokko" is a leading luxury furniture manufacturer in Japan, established in Tendo, Yamagata in 1940. Tendo Mokko has been creating numerous highly acclaimed furniture, including works with globally renowned designers and architects such as Mr. Sori Yanagi and Mr. Kenzo Tange, respectively. TAD celebrates its first collaboration with Tendo Mokko.

In the "SILENT Enclosure", their skillful techniques of artisan craftsmanship are incorporated, elevating the supreme functional beauty to yet another level.

INSTALLATION AND CARE

Precautions regarding the installation location

Do not install the speaker system in areas exposed to direct sunlight nor near heating appliances. Such conditions may result in shrinkage of the wood materials and finish, leading to deformation of the enclosure, discoloration, or damage to the speakers.

Conditions considered unpleasant by humans are detrimental to speakers as well. Providing a comfortable environment for the speakers will assist them in demonstrating their best performance. Please maintain the usage environment as follows:

Temperature: 15 °C to 25 °C (59 °F to 77 °F)

Relative Humidity: 35 % to 65 % (winter)
40 % to 70 % (summer)

- When using room air-conditioners or stoves to rapidly cool or heat room spaces, take precautions to avoid excessive dehumidification.
- Avoid placing the speaker near areas such as windows, as outside air can cause condensation to occur within the speaker.





Precautions during installation

- This speaker system has a total weight of 46 kg (101.4 lbs). Be sure that the installation location has a surface fully capable of supporting this weight.
- Further, when using the spikes, each spike will bear a load exceeding 15 kg (33 lbs), potentially leading to the production of marks or depressions in the surface contacted by the spike. In order to avoid such damage, either use the supplied spike bases, or other spike base material with the strength and sufficiently large area to support the spike safely.
- When spikes are used with the speaker system, scratches may be produced on the floor if the speaker is moved. To prevent such damage, it is recommended to remove the spikes before moving the speaker.
- Since this speaker system weighs 46 kg (101.4 lbs), it is extremely dangerous to attempt to install spikes while tilting the speaker. Lay the speaker on its side on a soft mat or carpet to prevent damage to the speaker, and always work with two or more persons. When installing the spikes take adequate care both to prevent pinching your fingers under the speaker and to prevent the speaker from falling over.

Installation

Installation on floor or rack

An aluminum plate can be found on the bottom surface of the speaker cabinet. In locations with a perfectly flat floor or other mounting surface, the speaker may be installed directly on the surface. The speaker system is also furnished with two kinds of spikes and cork sheets to allow selection of the optimum installation method for the chosen installation surface. Select the installation method in conjunction with the following tips:

	Installation location	Spike
Cork sheet	Flat surface	
Cone-shaped spikes	Flat surface	  <p>When using the coneshaped spikes, use the provided spike bases to prevent marking of the installation surface.</p>
Round spikes	Floors with carpets and other uneven surfaces where use of the cone-shaped spikes (with spike bases) would not provide sufficiently stable support.	

Installation using speaker stands (sold separately)

This speaker system has been designed as a “bookshelf” type speaker. As a result, when mounted directly on the floor, bass sounds may be amplified as a result of reflection from the floor surface, potentially creating unpleasant listening effects. In such cases, a speaker stand can be used to elevate the speaker from the floor surface. In general, optimum performance will be produced by mounting the speaker system so that the high-range speakers (tweeters) are roughly at the listener’s ear level. For this purpose, we recommend the use of the TAD speaker stand TAD-ST1 (sold separately).

When using the TAD-ST1, always fix the speaker system to the stand using screws to help prevent the speaker from falling. For details, consult the Operating Instructions accompanying the TAD-ST1.

• Dedicated Speaker Stand TAD-ST1 (sold separately)

To elicit the best possible performance from the TAD Compact Reference speaker system, TAD has engineered the dedicated speaker stand TAD-ST1 (sold separately). These stands have been optimized to assure high damping characteristics and stable barycentric positioning.

Installing The Spikes



CAUTION

Please be sure to screw all the way in when installing spikes.

The use of spikes on the bottom of the speaker system allows the creation of a secure contact between the speaker cabinet and the installation surface. The base of the speaker cabinet is provided with three points for the installation of the spikes. By supporting the speaker at these three points, secure contact can be established between the speaker and installation surface without the need for adjusting the height of the spikes. See *Choosing Where To Place The Speakers* on page 10 for help deciding where to place the speaker, and Figure 4 for how to install the spikes. There are screw holes on the aluminum plates located on the bottom of the cabinets.

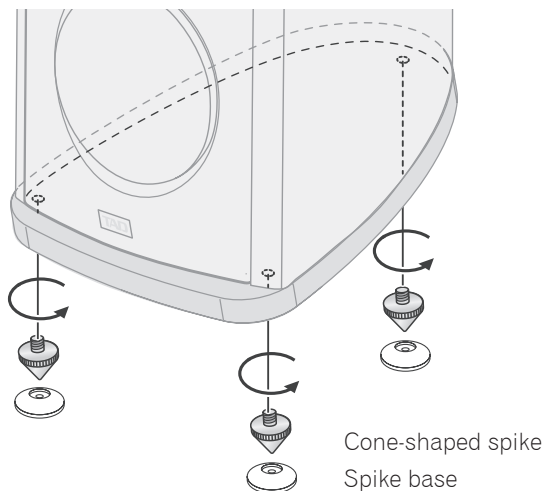
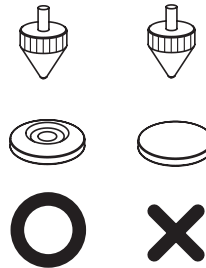

Figure 4: Installing spikes on the base of the TAD Compact Reference speaker system



CAUTION

- Be sure to place the spike bases as shown, with the depression facing upward toward the spike.



Removing The Grille Covers

The bass driver come equipped with a grille cover that should be removed when the speaker are in use (see Figure 5). To remove it, grasp the grille along the edges, pull it out, and store it in a safe place in case of future use when moving or storing this unit.

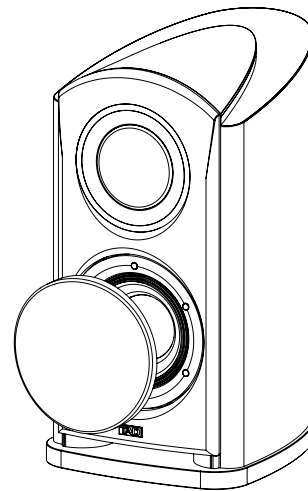

Figure 5. Removing the grille from the TAD Compact Reference speaker system

Choosing Where To Place The Speakers

Speaker placement within the listening room will have a great impact upon the total performance of TAD Compact Reference speaker system in terms of bass performance, tonal accuracy, and imaging. All rooms are different and so this section is intended as a guide only. Experimentation in your room will yield optimum results.

Begin by placing the rear of the speakers approximately one to two feet in from the front walls and the sides one to two feet in from the side walls of your listening room, as shown in Figure 6. Your listening position should be roughly equal to the distance between the two speakers. Also, turn the speakers inward so each axis points toward the listening position.

Next, connect the audio system as described in CONNECTING THE SPEAKERS on page 11. Then, optimize the speaker placement as described in OPTIMIZING THE SYSTEM on page 15.

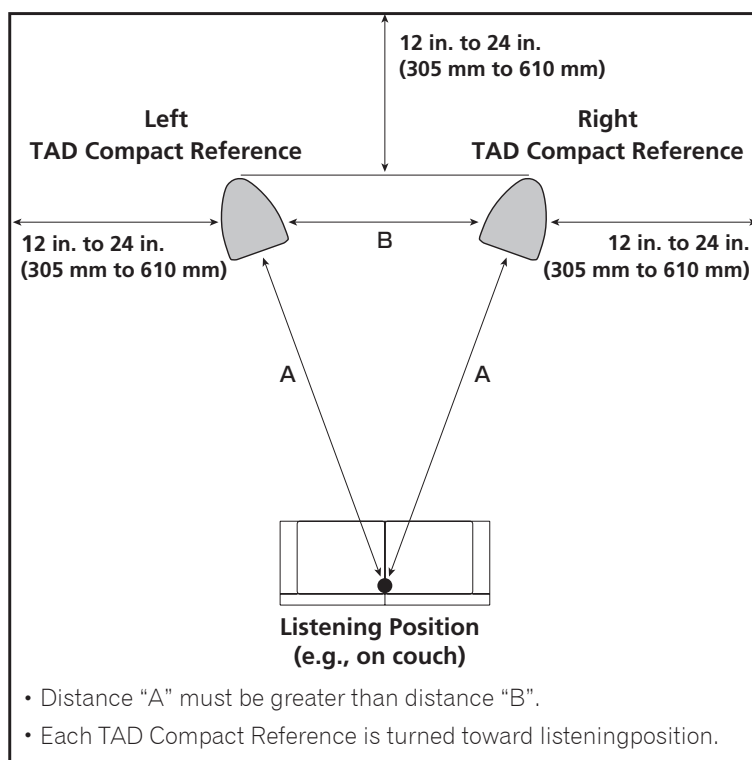

Figure 6. Placement of a pair of TAD Compact Reference speakers for stereo music listening

Speaker care

The unit is crafted with a painted finish. Wipe the cabinet surface gently with the accessory cleaning cloth to remove dust and fingerprints.

⚠ CAUTION

- When dusting the cabinet, do not use cleansers, abrasives or chemically impregnated cloths.
- Contact with alcohol, benzene, insecticides or other chemicals may cause peeling or discoloration of the finished surface.

⚠ CAUTION

- When connecting speakers or other components, always turn off the power to the amplifier, and disconnect the power cord.
- Speaker cables are not furnished with this speaker system, and must be purchased separately.
- After connecting the speakers, gently pull on the speaker cables to confirm that each cable wire is connected securely to its respective terminal. Loose connections may result in interrupted sound or noise.
- Do not allow wires from one connector or cable to touch those from another, since excessive load may be applied to the amplifier, causing the amplifier to stop operating or be damaged.
- If the polarity (+/–) of either right or left speaker is mistakenly reversed when connected to the amplifier, the speakers will be unable to produce proper stereo phase effect.

Single-Wire Connections

For single-wire connections, connect the high- and low-frequency sections of the crossover network with the shorting link that was included with this unit, then connect the (+) wire from your amplifier to either red binding post and the (–) wire from your amplifier to either black binding post, as shown in Figure 7.

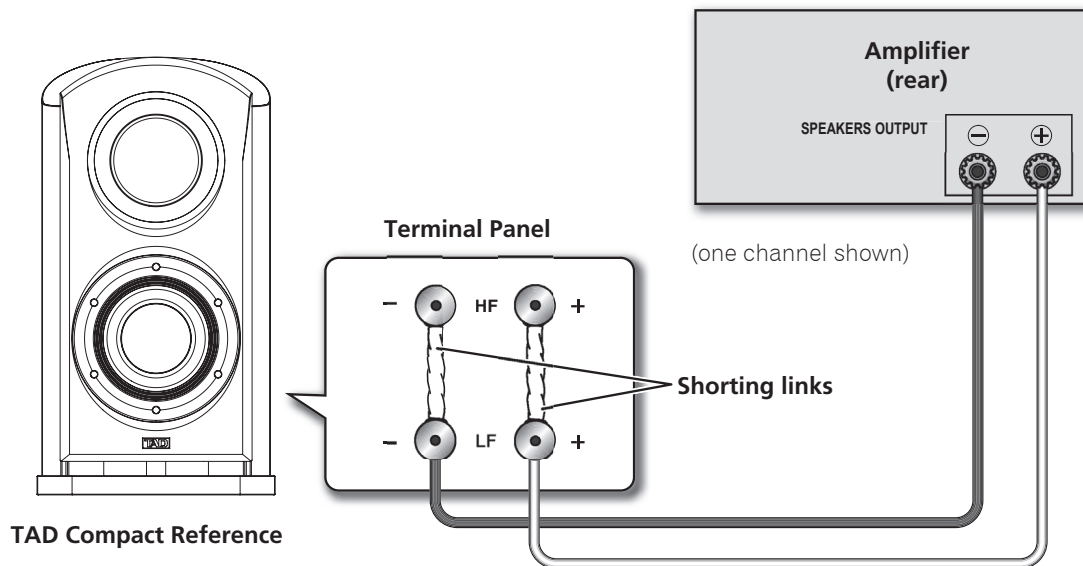

Figure 7. Connecting a TAD Compact Reference speaker in a single-wired system

Bi-Wire Connections

In a bi-wiring connection, you independently plug in the loudspeakers running from the amp to their respective high- and low-frequency plugs. This results in the CST driver and bass driver being independently connected directly to the amplifier, offering you the freedom to optimize the cable type for each of the drivers.

Connect one set of wires to the bottom set of binding posts (bass driver-specific network). Then connect a second set of wires to the top binding posts (CST-specific network). Next, connect both sets of wires to the appropriate terminals on your amplifier. Take care to connect both (+) wires to the (+) amplifier terminals and both (-) wires to the (-) amplifier terminals, as shown in Figure 8.



CAUTION

- Remove the shorting links before connecting speaker cables in bi-wiring connections.

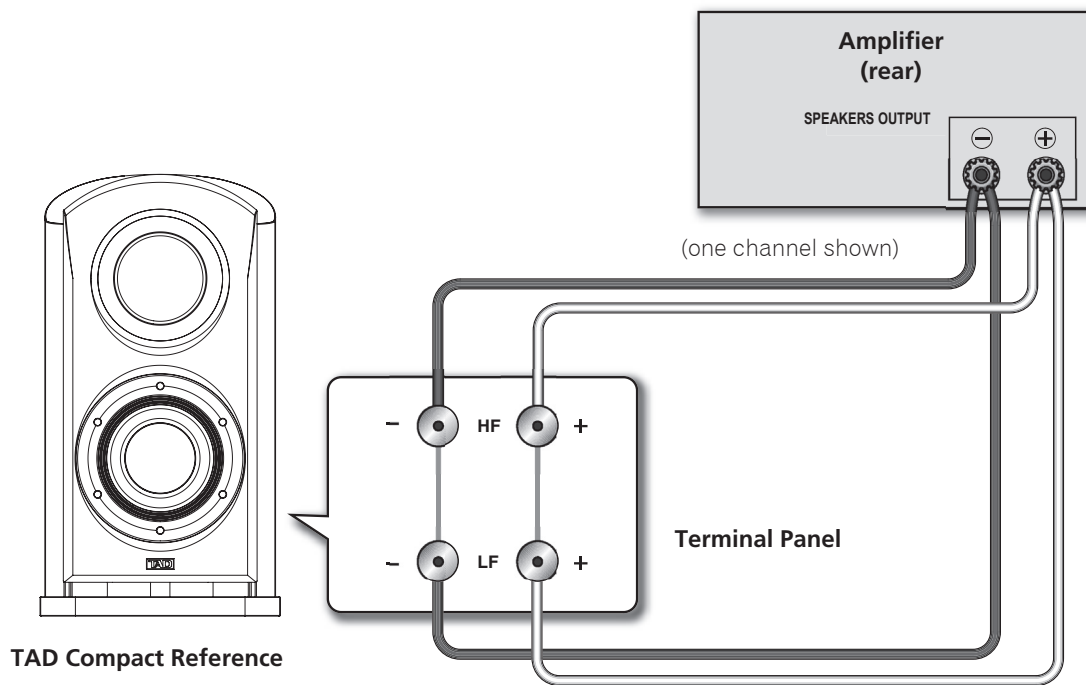

Figure 8. Connecting a TAD Compact Reference speaker in a bi-wired system

Bi-Amplification Connections

Bi-Amplification allows the best performance from the TAD Compact Reference speaker system by using dedicated amplifiers for low- and high-frequency sections. There are two possible configurations, commonly referred to as horizontal and vertical bi-amping.

CAUTION

- Remove the shorting links before connecting speaker cables in bi-amplification connections. Failure to do so may result in damage to your amplifiers.

Vertical Bi-Amping

With this configuration, identical stereo amplifiers are used for each speaker. One channel of each amplifier drives the low frequency section and the other channel drives the high frequency section, as shown in Figure 9. Connect one set of wires and amplifier channel to the bottom set of binding posts (bass driver-specific network). Then connect a second set of wires and the other amplifier channel to the top binding posts (CST-specific network). Take care to connect both (+) wires to the (+) amplifier terminals and both (-) wires to the (-) amplifier terminals.

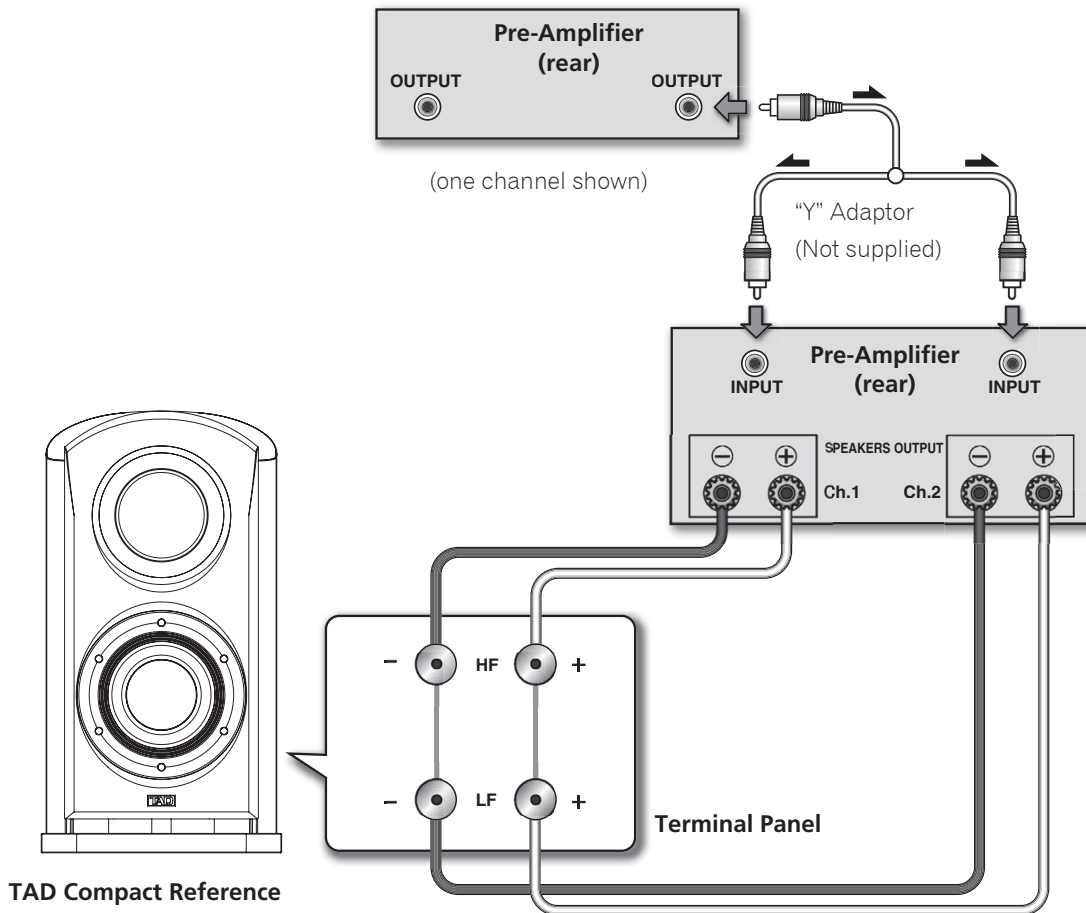

Figure 9. Connecting a TAD Compact Reference speaker in a vertical bi-amplified system

Horizontal Bi-Amping

With this configuration, you may use different stereo amplifiers for the low- and high-frequency sections of the speaker system (e.g., tube amplifiers for high frequency and solid state for low frequency). Each channel of one amplifier drives the low-frequency section of each speaker and each channel of the other amplifier drives the high-frequency section, as shown in Figure 10. This method requires that both amplifiers have the same gain; otherwise an imbalance will be heard between the low- and high-frequency reproduction from the speaker system. If in doubt, please consult your TAD dealer.

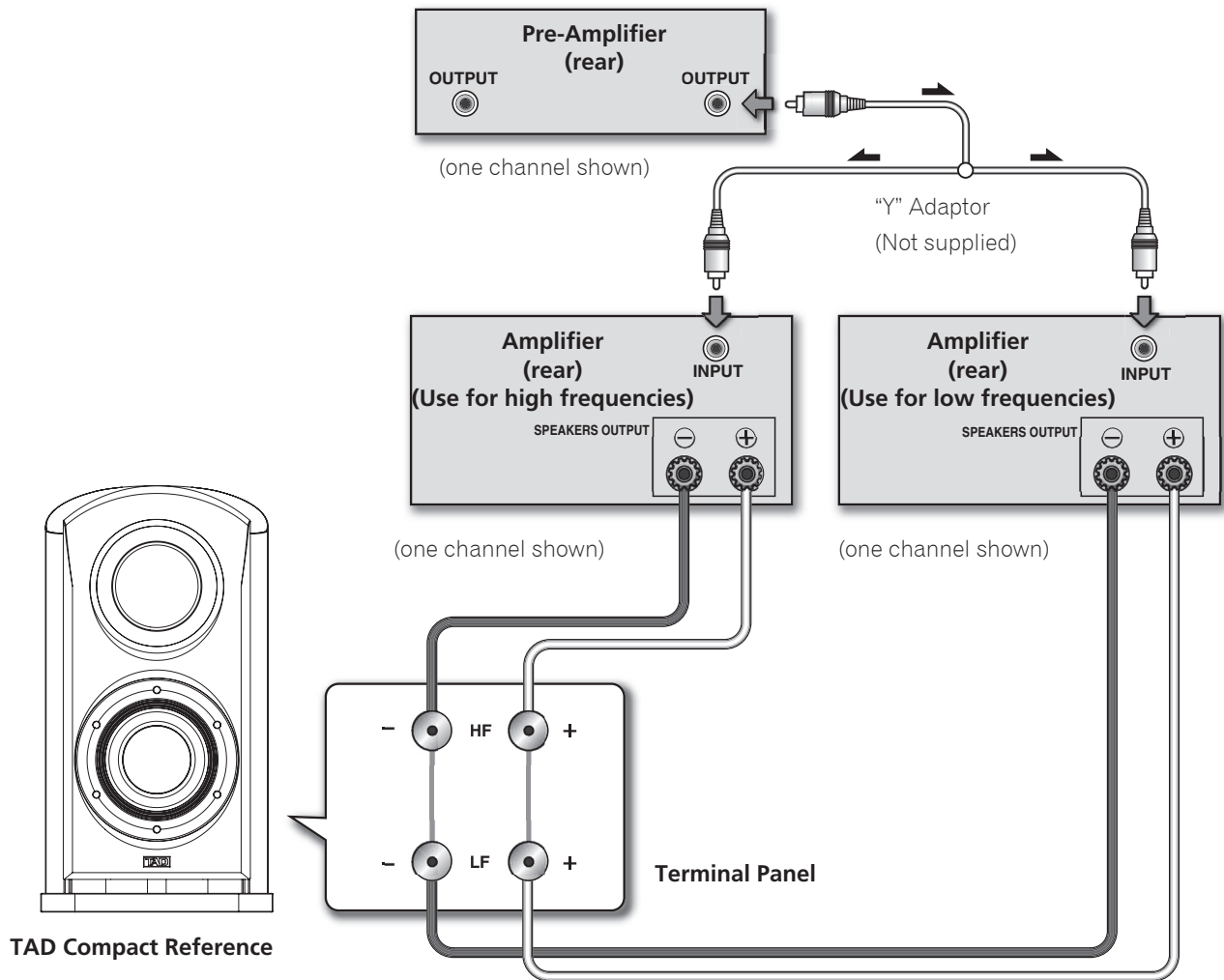

Figure 10. Connecting a TAD Compact Reference speaker in a horizontal bi-amplified system

Improving Bass Performance

Select a music track with well-recorded bass, such as acoustic string bass. Listen for all the bass notes having roughly equal level. If any notes jump out at you more strongly than others, try moving the TAD Compact Reference speaker system until you get the most even progression of the notes.

Typically, moving them towards the walls will increase low bass output, but can result in more unevenness higher up the musical scale. Moving them closer to the side walls will not produce the same effect as moving closer to the back wall, so try experimenting moving both ways for the most pleasing sound. Also listen to drum sounds. The kick drum should sound tight and fast, without low-frequency boom. Changes in speaker position of as little as a few inches can have a large effect upon bass performance, so take time and try many positions.

A useful tip to speed up the process is to have a partner move around the room while talking. Listen to where the voice sounds most natural, without added chestiness, and position the speaker system in that location.

Improving Imaging

Now select music with a strong center image. Listen for that image to be exactly centered between the speakers, and to be well-focused. If the image is unclear and spreads wide, the side walls are probably creating strong reflections. Try moving the speakers closer together to reduce this effect. If this brings them too close, try instead toeing in the speakers so that the axis crosses in front of the listening position. Because of the superior off-axis performance of the CST driver, the strength of the sidewall reflections will be reduced, and at the same time, the image will be stabilized and focused.

Now listen to music with well-recorded acoustics. Check that the image is wide and deep. Limited depth suggests that the speakers are placed too close to the front wall. Try moving them forward.

Final Optimization

You may find that as you move the speakers to optimize one aspect of performance another worsens; for example, trading improved image accuracy for poorer bass response. If this occurs, try moving your listening position. Bass response is governed strongly by both speaker and listening positions, whereas imaging is mostly determined by the speaker position. Therefore, you may find that if optimizing for imaging compromises bass, then changing the listening position will bring back bass performance. The room characteristics will also have a profound influence upon the sound. Live rooms, with few soft furnishings and hard floors, will impart an artificial sense of spaciousness to the sound but reduce the intimacy and accuracy. Overly dead rooms, with lots of furnishing, carpets, and drapes will produce a very dry, lifeless sound and require lots more power to drive the speaker system to adequate sound levels. The optimum is somewhere inbetween. Avoid hard, unbroken, parallel walls, especially side walls, as these impart strong flutter-type echoes and will have a bad influence on the imaging. Try and break up long expanses of walls with drapes, wall hangings, or bookshelves, and try not to introduce too much asymmetry into the room layout, as this will also affect the imaging.

SPECIFICATIONS

Model Name

TAD Compact Reference

Model No.

TAD-CR1TX

Design

Bass reflex, bookshelf-type speaker

Drive units

Bass driver 20 cm (8 in.) cone
Midrange/Tweeter
.....concentric 16 cm (6 1/2 in.) cone/ 3.5 cm (1 3/8 in.) dome

Performance Data

Frequency Range.....32 Hz to 100 kHz
Crossover Frequencies..... 250 Hz, and 2 kHz
Amplifier Requirements..... 200 W
Sensitivity86 dB @ 2.83 V and 1 m (anechoic conditions)
Impedance 4 ohms

Physical Data

Weight 46 kg (101.4 lb)

Dimensions

Height 628 mm (24.7 in.)

Width 341 mm (13.4 in.)

Depth 446 mm (17.6 in.)

Supplied accessories

Accessory kit

- Cleaning cloth x 1
- Shorting links x 2
- Cone shaped spike x 3
- Round spikes x 3
- Spike bases x 3
- Cork sheets x 3
- This Owner's Manual (English) x 1
- Owner's Manual (Japanese & French editions) x 1
- Warranty card (This warranty is valid only in Japan.)

Note

Included parts may vary slightly by region.

The specifications and construction details in this and related TAD publications are subject to change without notice. The TAD logo is a registered trademark of Technical Audio Devices Laboratories, Inc.

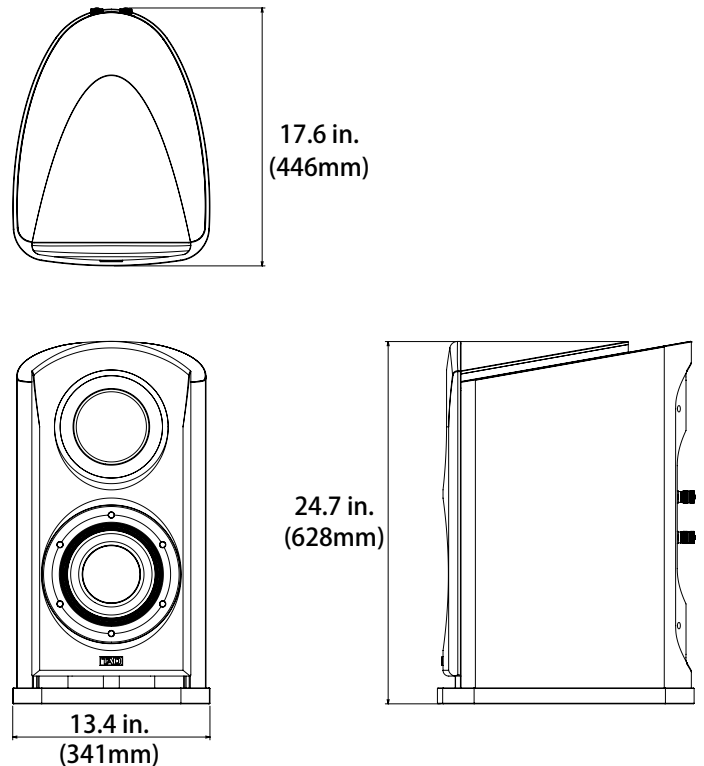

Figure 11. Overall dimensions of the TAD Compact Reference speaker system

The Safety of Your Ears is in Your Hands

Get the most out of your equipment by playing it at a safe level – a level that lets the sound come through clearly without annoying blaring or distortion and, most importantly, without affecting your sensitive hearing. Sound can be deceiving. Over time, your hearing "comfort level" adapts to higher volumes of sound, so what sounds "normal" can actually be loud and harmful to your hearing. Guard against this by setting your equipment at a safe level BEFORE your hearing adapts.

ESTABLISH A SAFE LEVEL:

- Set your volume control at a low setting.
- Slowly increase the sound until you can hear it comfortably and clearly, without distortion.
- Once you have established a comfortable sound level, set the dial and leave it there.

BE SURE TO OBSERVE THE FOLLOWING GUIDELINES:

- Do not turn up the volume so high that you can't hear what's around you.
- Use caution or temporarily discontinue use in potentially hazardous situations.
- Do not use headphones while operating a motorized vehicle; the use of headphones may create a traffic hazard and is illegal in many areas.

S001a_A1_En



TECHNICAL AUDIO DEVICES LABORATORIES, INC.

© 2019 TECHNICAL AUDIO DEVICES LABORATORIES, INC.
All rights reserved.

TECHNICAL AUDIO DEVICES LABORATORIES, INC.
Bunkyo Green Court, 2-28-8, Honkomagome, Bunkyo-ku, Tokyo 113-0021, Japan
<http://tad-labs.com>